

FIXTURE L10

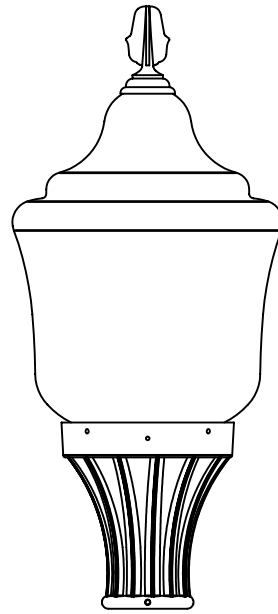

FIXTURE L11

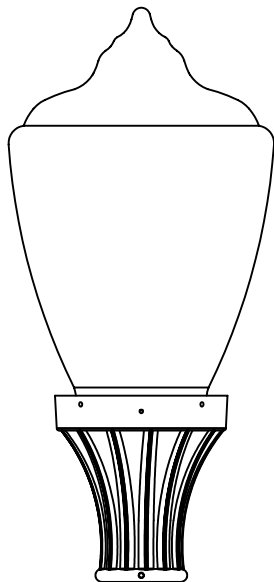

FIXTURE L12

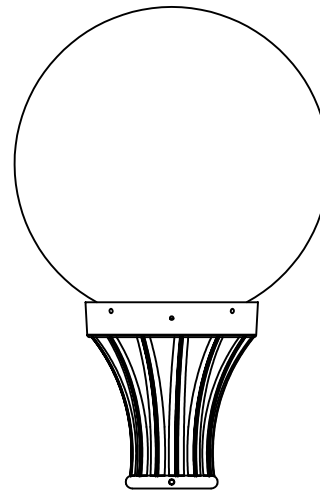

FIXTURE L13

L10, L11, L12 & L13
INSTALLATION
INSTRUCTIONS

⚠ CAUTION ⚠
 This type of warning note is used to indicate the possibility of damage to the electrical components within the fixtures.

⚡ WARNING ⚡
 This type of warning note is used to indicate possible fire or electrical shock hazards that may cause serious injuries or death.

IMPORTANT SAFETY INSTRUCTIONS

⚡ WARNING ⚡

TO REDUCE THE RISK OF FIRE, ELECTRICAL SHOCK, OR INJURY:

- 1 READ this manual before assembling or using your fixture.
- 2 Fixture should be installed by a licensed/qualified electrician.
- 3 This fixture must be wired in accordance with the NATIONAL ELECTRIC CODE and any applicable local codes.
- 4 Use this unit only in the manner intended by the manufacturer.
- 5 Before installing, servicing or repairing, switch off power to fixture and cover exposed wires to avoid risk of fire, shock or DEATH.
- 6 Make sure all wires are securely attached and covered with wire-nuts and/ or wire-clamps.
- 7 Tighten/ secure all fasteners, screws, nuts, clamps, etc.
- 8 Components not completely installed must not left unattended until properly secured in place.

SAVE THESE INSTRUCTIONS

		INSTALLATION DETAILS FOR L10 - L13 FIXTURES	
<small>THIS PRINT IS THE PROPRIETARY, INTELLECTUAL AND CONFIDENTIAL PROPERTY OF STONEBRIDGE LIGHTING AND MAY NOT BE USED OR REPRODUCED WITHOUT THE EXPRESS WRITTEN CONSENT OF STONEBRIDGE LIGHTING. ANY USE HEREOF OR OF ANY INFORMATION CONTAINED HEREIN SHALL BE FOR THE SOLE BENEFIT OF STONEBRIDGE LIGHTING OR ITS AFFILIATES. © 2008 STONEBRIDGE LIGHTING</small>			
DWG. No. L10 - L13_SA	DATE 12/30/2008	DRAWN BY: R. A. M.	APPROVED BY: M. K.
<small>UNLESS NOTED OTHERWISE ALL DIMENSIONS ARE IN INCHES ALL THREADS ARE UNC - 2A/B OR UNF 2A/B</small>			

TOOLS NEEDED FOR THIS INSTALLATION

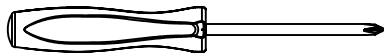

PHILLIPS HD. SCREWDRIVER



SET OF ALLEN WRENCHES

STEP 2: ATTACH ACORN/ GLOBE TO FITTER

SLIP ACORN/ GLOBE ONTO FITTER AND SECURE IN PLACE WITH FOUR (4) SET-SCREWS. DO NOT OVER-TIGHTEN!

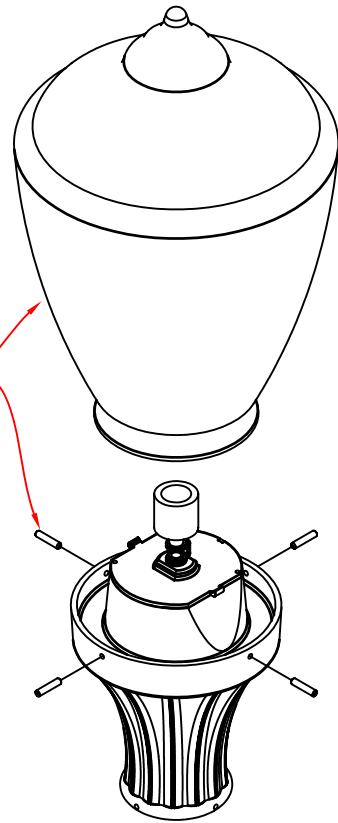

STEP 1: INSTALL FITTER CAP ASSEMBLY TO FITTER

FITTER CAP PROVIDED W/ NIPPLE, SOCKET & BALLAST (IF REQ'D) PRE-ASSEMBLED.

FASTEN TO FITTER WITH (2) #8-32 SCREWS, PROVIDED

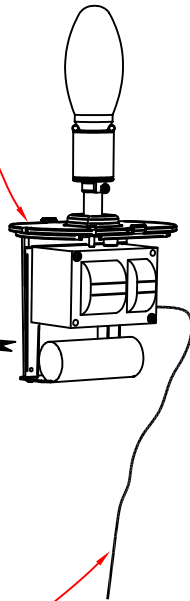

FEED WIRE LEADS THROUGH FITTER

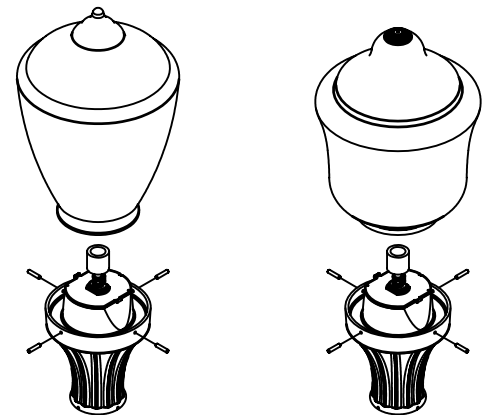
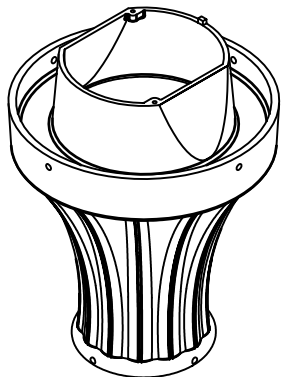

METHOD OF ATTACHMENT APPLIES TO ALL TYPES OF ACORNS/ GLOBES

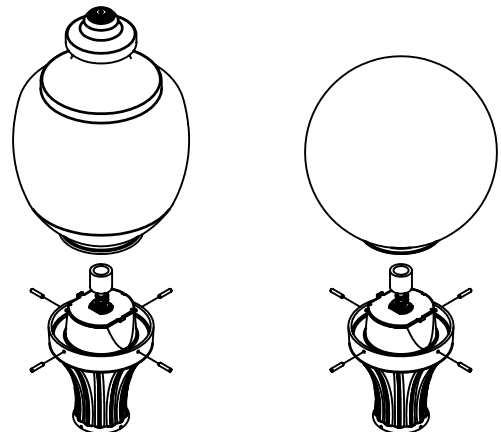

INSTALLATION DETAILS FOR L10 - L13 FIXTURES

THIS PRINT IS THE PROPRIETARY, INTELLECTUAL AND CONFIDENTIAL PROPERTY OF STONEBRIDGE LIGHTING AND MAY NOT BE USED OR REPRODUCED WITHOUT THE EXPRESS WRITTEN CONSENT OF STONEBRIDGE LIGHTING. ANY USE HEREOF OR OF ANY INFORMATION CONTAINED HEREIN SHALL BE FOR THE SOLE BENEFIT OF STONEBRIDGE LIGHTING OR ITS AFFILIATES. © 2008 STONEBRIDGE LIGHTING

DWG. No. L10 - L13_SA	DATE 12/30/2008	DRAWN BY: R. A. M.	APPROVED BY: M. K.
--------------------------	--------------------	-----------------------	-----------------------

UNLESS NOTED OTHERWISE

ALL DIMENSIONS ARE IN INCHES
ALL THREADS ARE UNC - 2A/B OR UNF 2A/B

STEP 3: ATTACH FIXTURE TO POLE

**FASTEN FIXTURE TO POLE
WITH (4) 1/4-20 SET-SCREWS,
(PROVIDED BY STONEBRIDGE)**

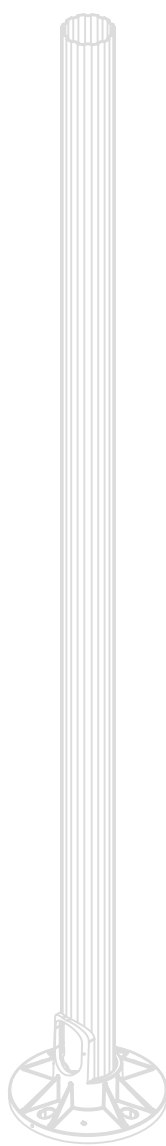
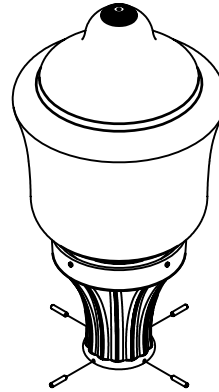
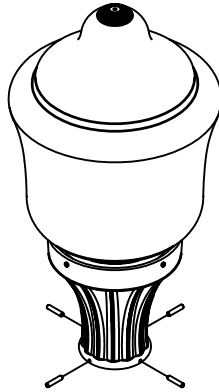
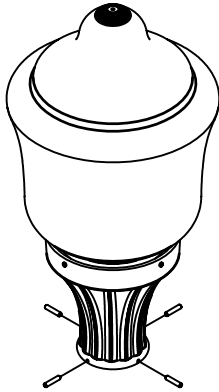

**METHOD OF ATTACHMENT
APPLIES TO ALL TYPES
OF ACORNS/ GLOBES**



**INSTALLATION DETAILS FOR
L10 - L13 FIXTURES**

THIS PRINT IS THE PROPRIETARY, INTELLECTUAL AND CONFIDENTIAL PROPERTY OF STONEBRIDGE LIGHTING AND MAY NOT BE USED OR REPRODUCED WITHOUT THE EXPRESS WRITTEN CONSENT OF STONEBRIDGE LIGHTING. ANY USE HEREOF OR OF ANY INFORMATION CONTAINED HEREIN SHALL BE FOR THE SOLE BENEFIT OF STONEBRIDGE LIGHTING OR ITS AFFILIATES. © 2008 STONEBRIDGE LIGHTING

DWG. No. L10-L13_SA	DATE 12/30/2008	DRAWN BY: R. A. M.	APPROVED BY: M. K.
------------------------	--------------------	-----------------------	-----------------------

UNLESS NOTED OTHERWISE
ALL DIMENSIONS ARE IN INCHES
ALL THREADS ARE UNC - 2A/B OR UNF 2A/B